

Dafo Vulcan Fire Suppression System is a completely pressure less system. Quality and reliability is proven by passing the new UNECE R107 standard. Convenient assembly and long service intervals are other advantages that are achieved with the unique design Vulcan offers.



DAFO VULCAN FIRE SUPPRESSION SYSTEM FOR BUSES



Dafo Vulcan Fire Suppression System is specially developed to meet the demands within the bus sector.

A completely pressure less system!

Vulcan is not depending on any pressurized components, Vulcan eliminates the risk of false release and malfunction due to lost pressure.

Limited Service Demand!

The actuator in Vulcan is maintenance free for 15 years and our Forrex suppression agent for 10 years, contributing to a very low Total Cost of Ownership during the lifetime of your bus.

Fast installation!

Vulcan's unique design, with its reduced number of components will increase productivity and save valuable time. Your installation will be faster, you'll save space in your bus and the need for service is limited.

The liquid agent extinguishes fire in less than a second and effectively prevents re-ignition. A completely pressure less system that demands modest space and that operates down to -50° C.



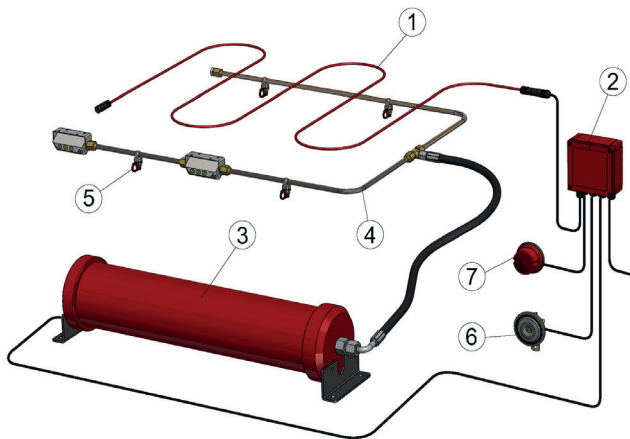

Many of the world's leading bus manufacturers trusts Vulcan to protect their passengers and assets. The flexible, fully automatic system detects and suppress the fire in less than a second.

The Vulcan container is totally orientation independent upon installation and easy to fit. Actuation is not depending on any pressurized components, detection is achieved through a linear heat detector wire which detects the fire in a very early stage. Means to manually release the system can be provided upon request. The agent is distributed through a pipe system with specially designed nozzles that effectively covers the protected area and suppress the fire.

FUNCTION

Fire is indicated by a linear heat detector wire (1) that sends a signal to the control unit (2) and release the agent container (3) that distributes the Forrex liquid to the nozzles (5) through the pipe system (4). At the same time the alarm system is activated, an alarm horn (6) in the bus and a light signal in the panel will warn the driver (7).

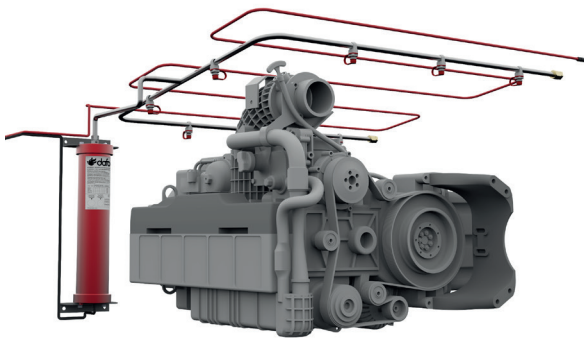

PRESSURE LESS SYSTEM - HIGH RELIABILITY

Vulcan is not depending on pressurized components, this ensures that the risk for malfunction or false release due to lost pressure is eliminated. Since Vulcan is a pressure less system it is also more convenient to transport and install.

LESS COMPONENTS - FAST INSTALLATION

Faster installation time and less material handling in your internal processes are important factors in the strive for constant improvements. Dafo is with Vulcan reducing the number of components in our system. This saves space, reduce your installation time and contributes to your success.

SERVICE - LOW TCO

The unique Vulcan design minimizes the amount of services needed and lowers your TCO (Total Cost of Ownership). Every year a normal inspection is performed and every 10th year the liquid shall be replaced. Our worldwide network of authorized service partners are available to support you and will ensure that the service is performed according to Dafo standards.

CERTIFICATES - DAFO QUALITY

The Vulcan system is tested and approved according to UNECE R107. To ensure functionality during harsh conditions Vulcan is also EMC, vibration and temperature tested according to vehicle standards.

VULCAN BENEFITS

- Vulcan is a pressure less system, so there is no risk for malfunction or false release due to lost pressure.
- Fast installation, few components achieve a cost-effective installation and it minimizes the need for service.
- Service interval for actuator is 15 years, Forrex agent 10 years, Vulcan helps you to reduce your Total Cost of Ownership.
- Reliable detection, our linear detection wire is a secure and fast method to detect a fire and release the system.
- UNECE R107 approved
- The Vulcan container is orientation independent giving you, the freedom to install it in a position which suits you the best.



vehicle fire protection